

Compact vertical mast

- Working height: 5.70 m
- Compact dimensions
- Weight: 776 kg
- Usable indoors or outdoors





60 V

 Capacity :
 Indoor use.....227 kg including 2 people
 Outdoor use.....including 1 people

 Working height.....5.70 m
 Platform height.....3.70 m

 Overall length.....1.36 m
 Overall width.....0.76 m
 Folded height.....1.70 m
 Basket internal dimensions:
 width x length.....0.74 m x 1.04 m
 Ground clearance.....7.6 cm
 Turning radius(inside)0.37 m
 Turning radius(outside)1.40 m

 Battery.....24 V/220 Ah
 Built-in charger90 V to 240 V

 Travelling speed.....3.65 km/h
 Working speed.....1.0 km/h

 Gradability.....25%

 Tyres.....not marking
 Drive wheels.....2 (front)
 Steering wheels.....2 (front)

 Weight.....776 kg

Standard equipment:

- Proportional controls
- Travel at maximum height possible
- Descent and slope alarm
- 25A automatic charger built in
- Emergency lower controls on base
- Non marking tyres
- Crane lifting point
- Anti-roll bar
and parking brake
- Selectable motion alarm

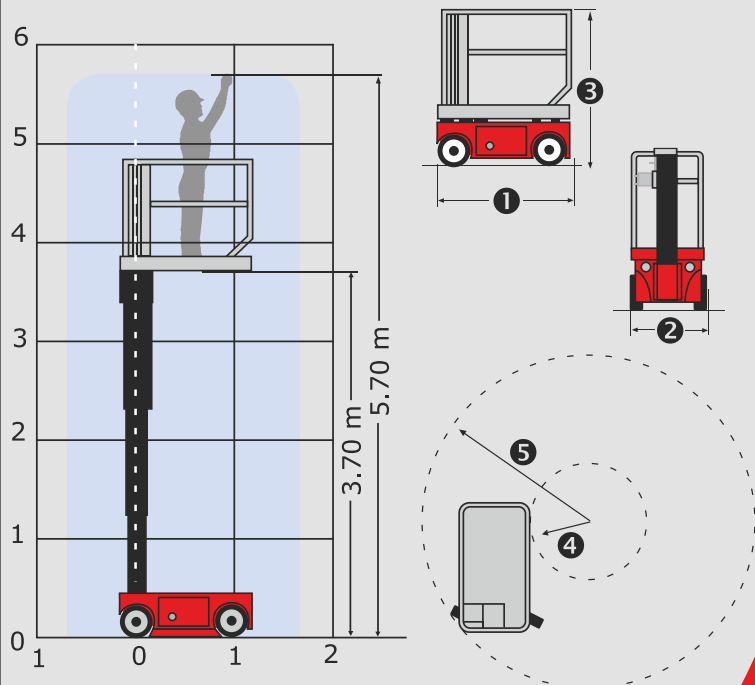

The specifications given are not binding to the manufacturer and can be modified without prior notification.
 The equipment shown in this leaflet may be standard, optional or unavailable depending on the version. For further details, please contact your MANITOU dealer.
 Complies with the machine directive (98-37-CE) and standards in the countries where the machine is delivered.